

Note: We don't have enough accessible pins, so we share some between UART, charge controller and pushbuttons. Should work okay as long as they do not operate at the same time.

Sheet: /	
File: W53.sch	
Title:	
Size: A4	Date:
KiCad E.D.A. kicad 5.1.9	
Rev:	
Id: 1/5	

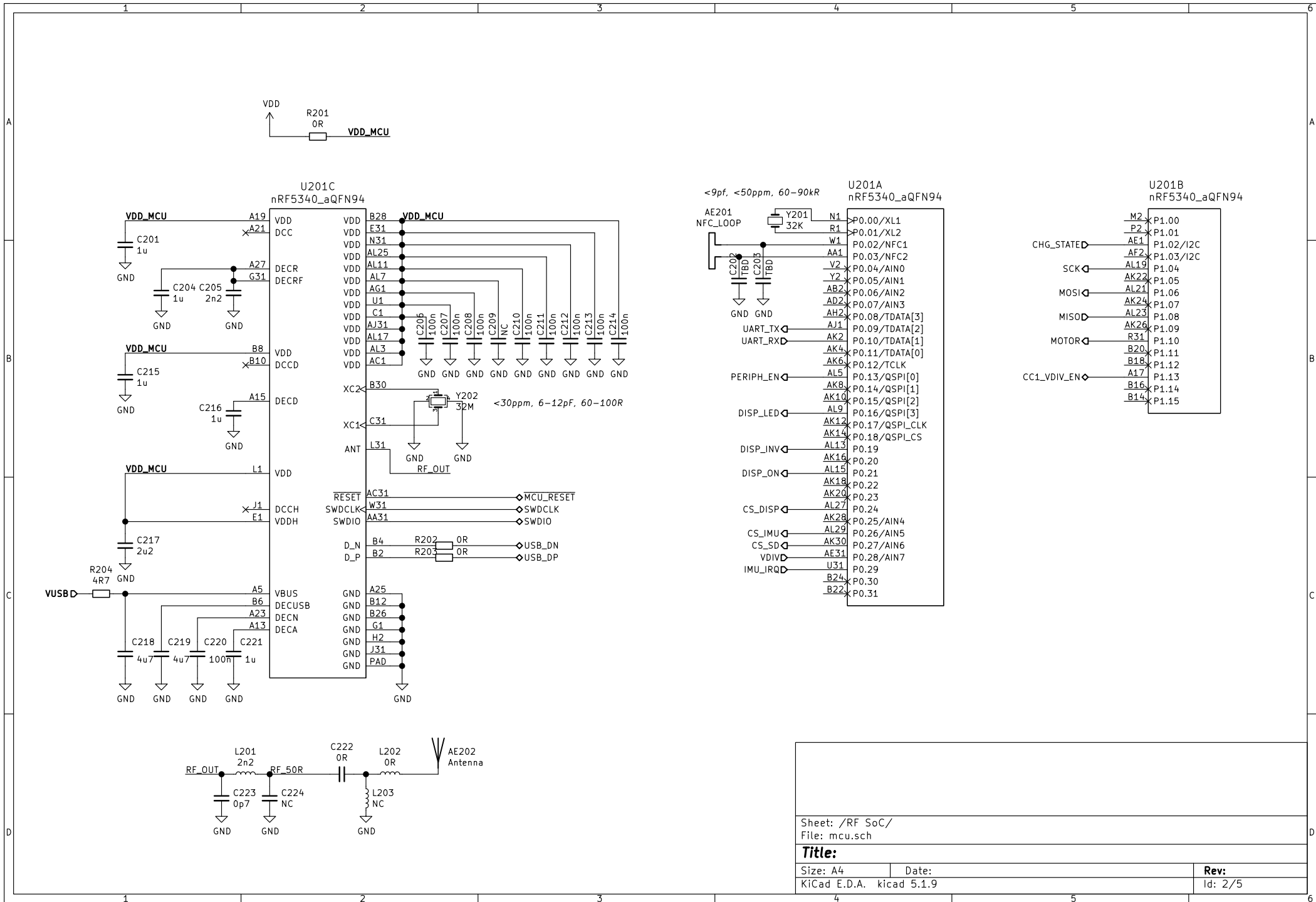

Sheet: /RF SoC/		File: mcu.sch	
Title:			
Size: A4	Date:	Rev:	
KiCad E.D.A. kicad 5.1.9		Id: 2/5	

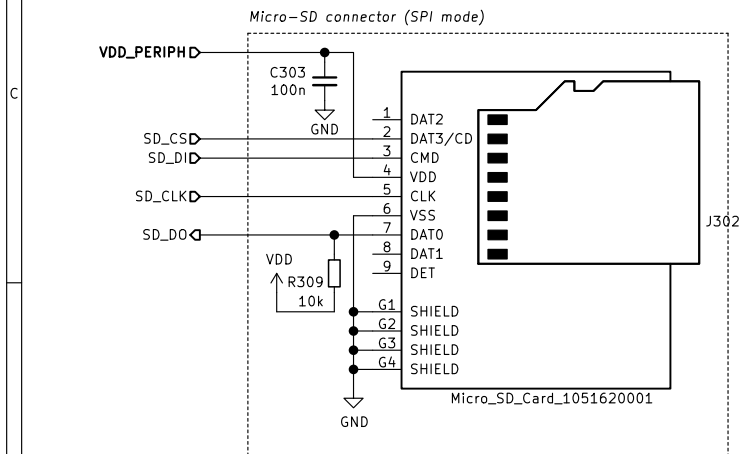
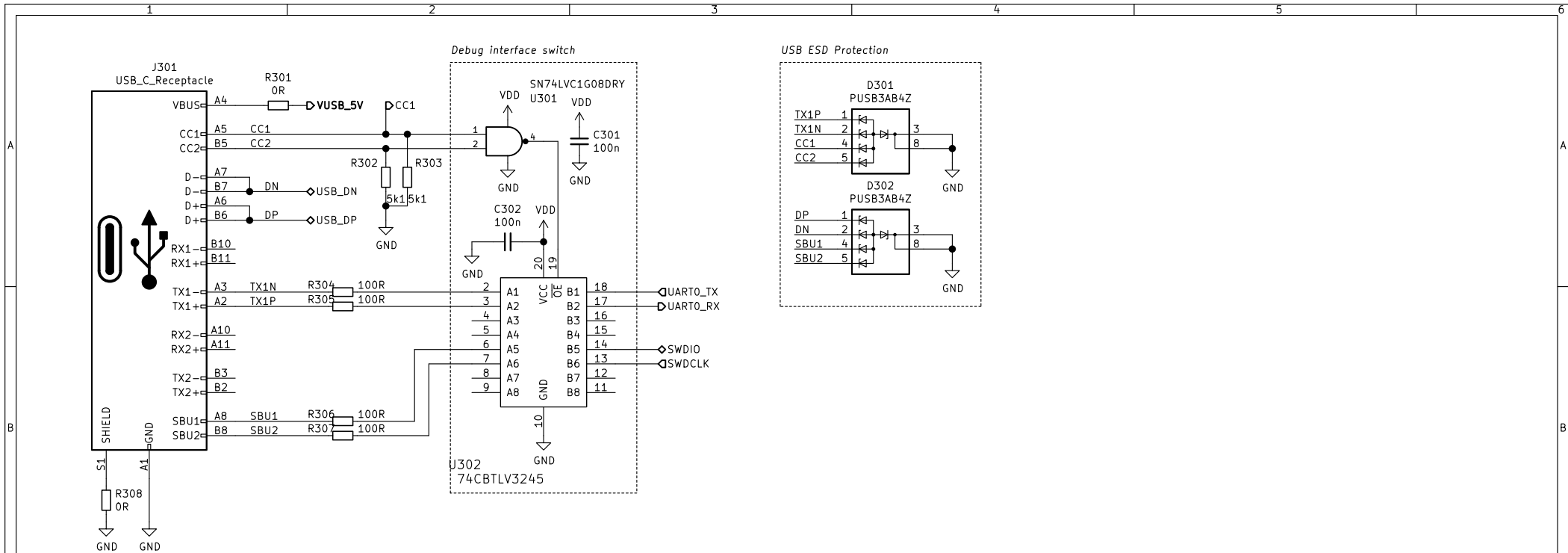

Sheet: /Connectors/
File: conn.sch

Title:

Size: A4
KiCad E.D.A. kicad 5.1.9

Date:

Rev:
Id: 3/5

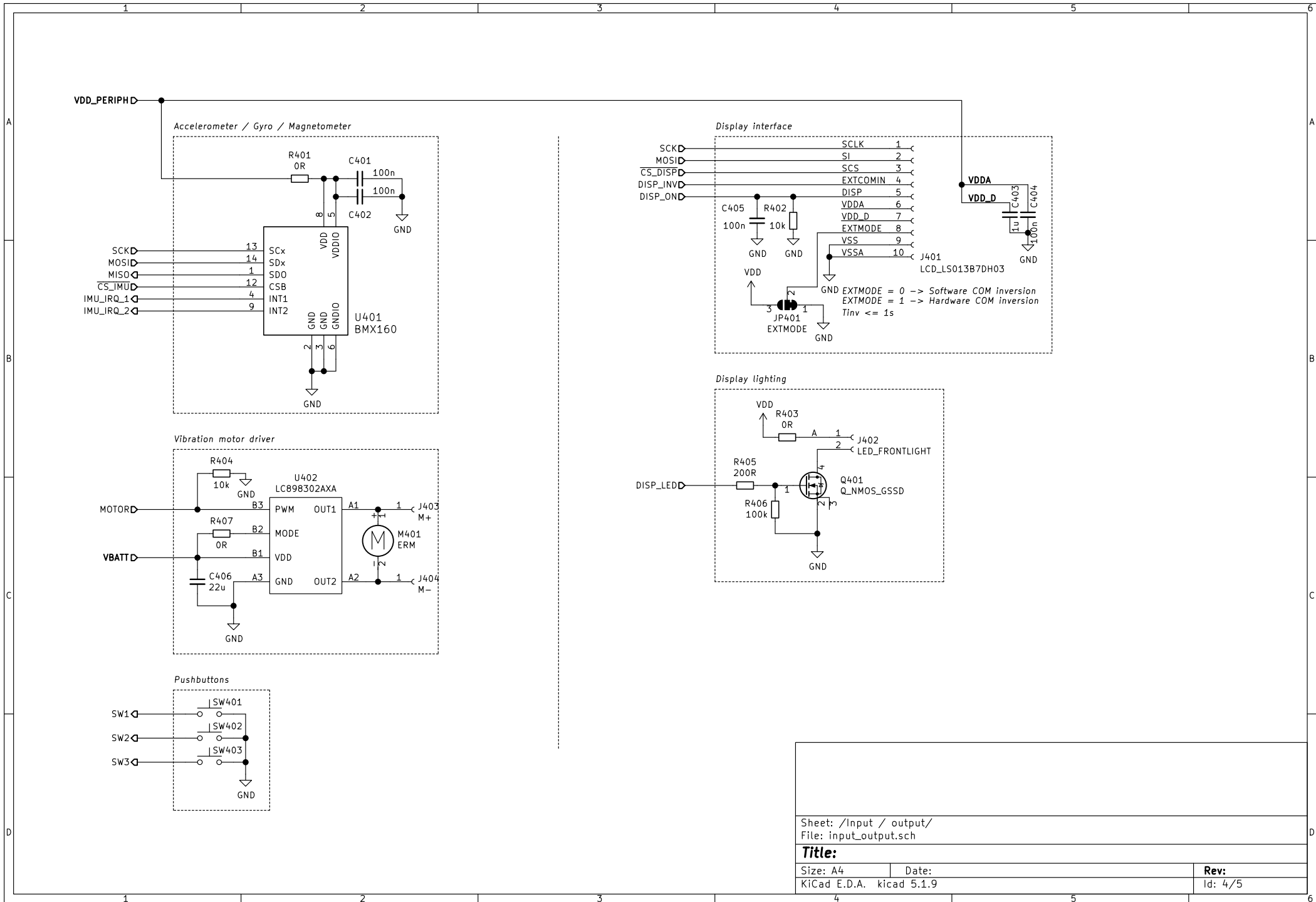

Sheet: /Input / output/
File: input_output.sch

Title:

Size: A4

Date:

KiCad E.D.A. kicad 5.1.9

Rev:

Id: 4/5

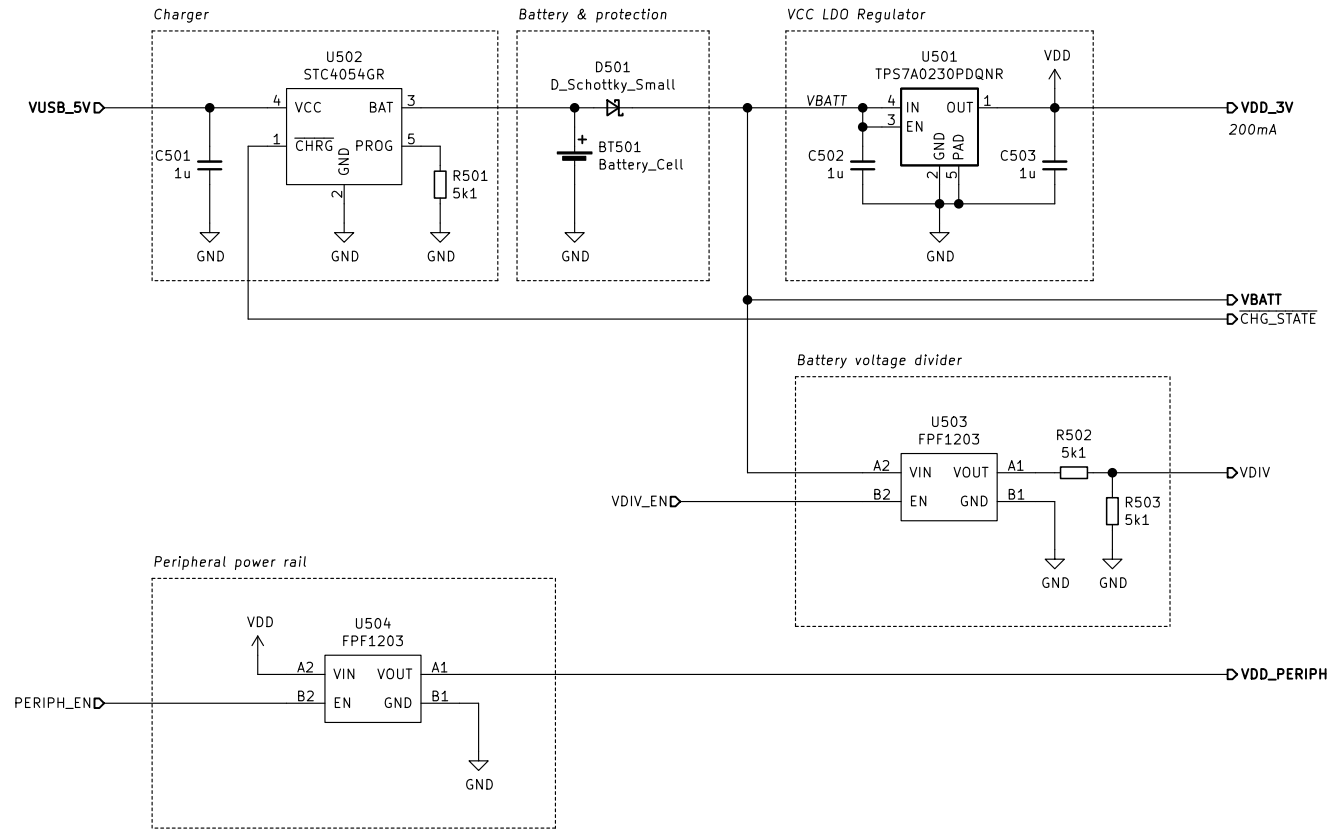

Sheet: /Power/
File: power.sch

Title:

Size: A4
KiCad E.D.A. kicad 5.1.9

Date:

Rev:
Id: 5/5